

# MaxxForce<sup>®</sup> 12.4D

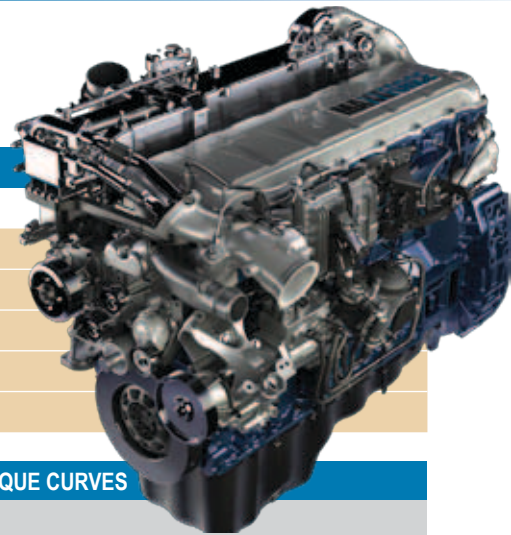

**NAVISTAR<sup>®</sup>**  
DEFENSE

## MAXXFORCE® D



### MAXXFORCE® 12.4D

#### Defense Diesel Engine

Power Output (HP)	450-550 (335-410 Kw)
Torque Range (lb-ft)	1450-1800 (1904-2448 Nm)
Idle RPM	700
Governed RPM	2100
High Idle RPM	2200

### KEY FEATURES

#### Premium Heavy-Duty Commercial Construction

- High pressure common rail fuel system
- JP8 compatible
- Single stage wastegate
- Compacted Graphite Iron (CGI) block
- Wet replaceable sleeves
- One piece steel pistons
- Electronic Control Module (ECM)
- SAE #1 and #2 flywheel housing
- Glow plug with cold start solenoid
- Diamond Logic electronic control features
- J1939 datalink compatible; diagnostic data stored in ECM
- Cold weather ambient protection; service assistant
- Remote "2" Preset PTO engine speed
- Remote variable engine speed control
- Engine weight (dry): 2400lbs (1089kg)

### MARKET AVAILABILITY

Medium and Heavy Wheeled Military Vehicles  
Medium Tracked Military Vehicles

### MAXXFORCE 12.4D POWER PACK AVAILABLE

Transmissions  
Cooling System  
Full Accessory Options  
Driveline Components

### ENGINE DIMENSIONS

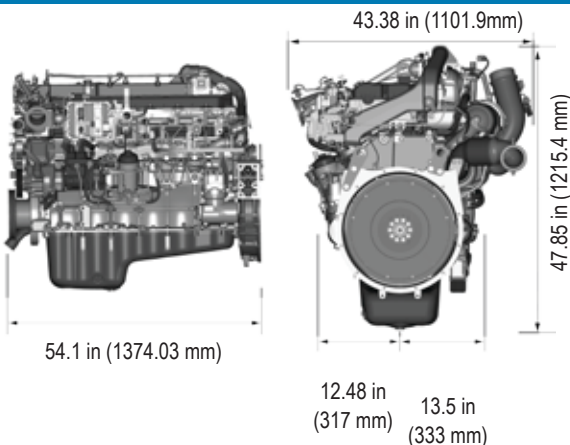

### MAXXFORCE 12.4D HORSEPOWER / TORQUE CURVES

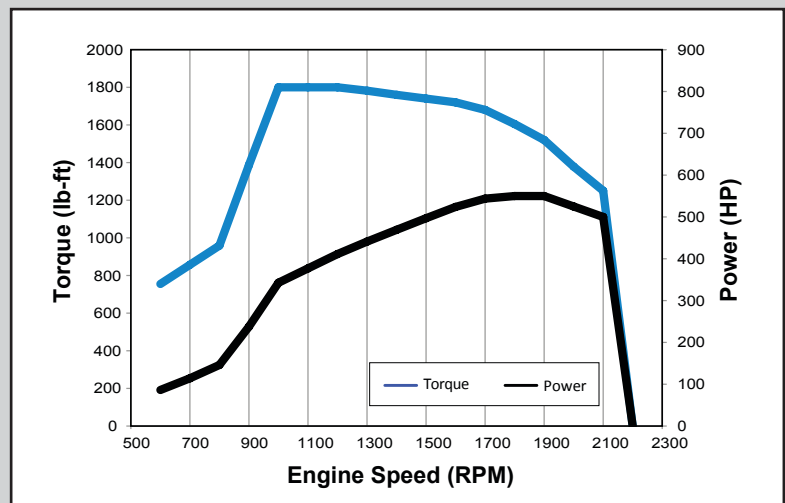

### MAXXFORCE 12.4D POWERED VEHICLES



ATX 6x6



MaxxPro Tractor



ATX 8x8