

MaxxForce[®] 9.3D

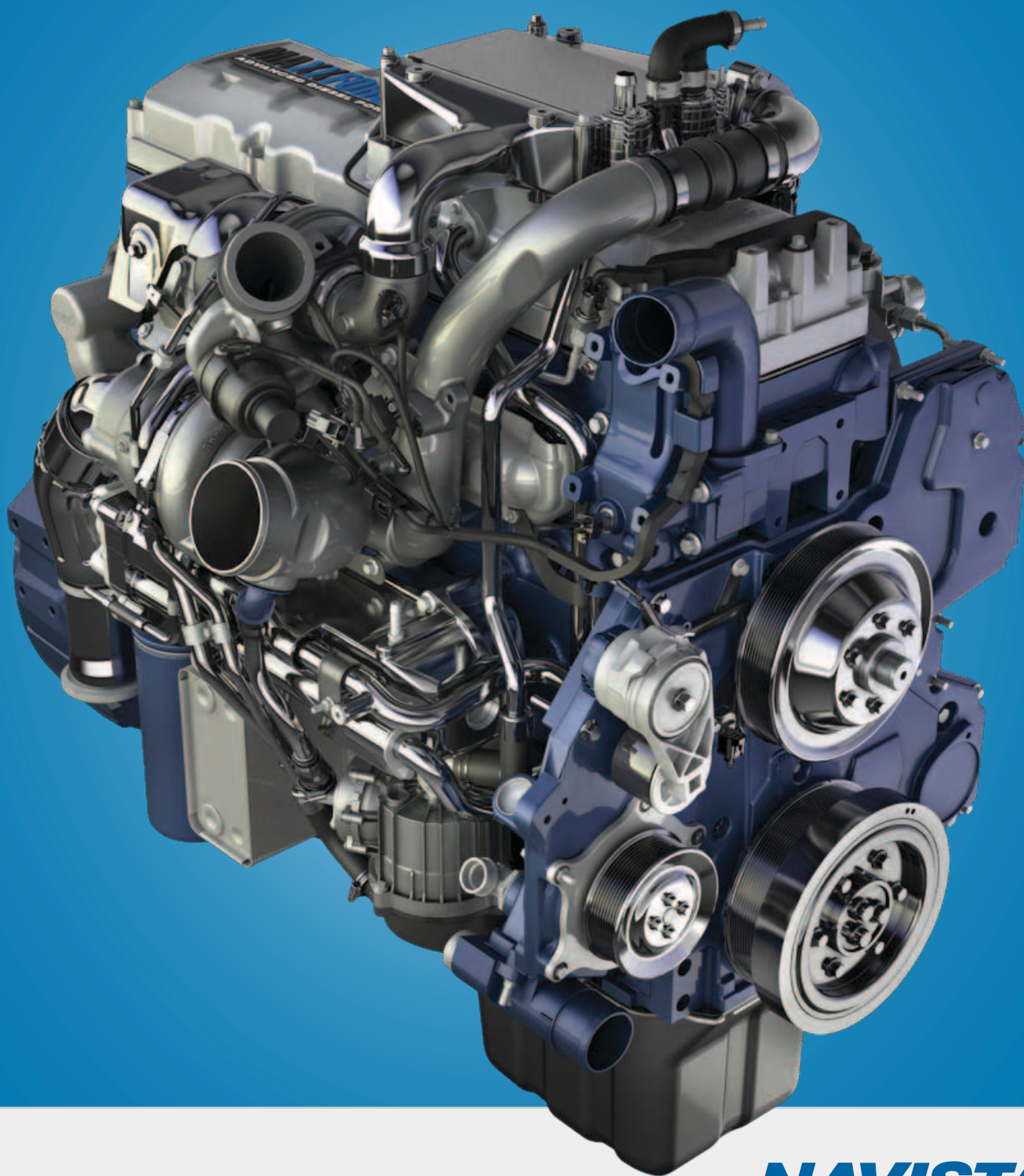

NAVISTAR[®]
DEFENSE

MAXXFORCE® D

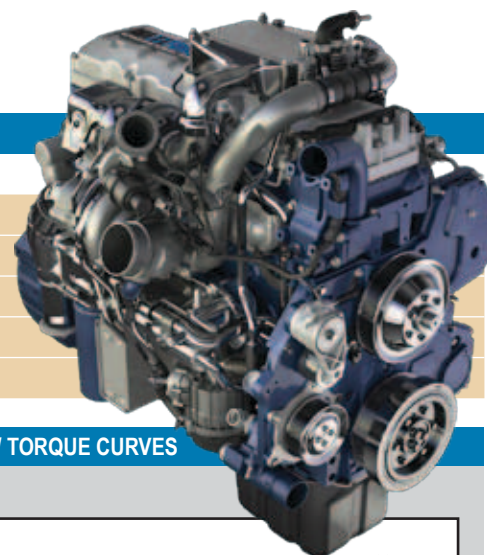

MAXXFORCE® 9.3D

Defense Diesel Engine

Power Output (HP)	375-465 (280-347 Kw)
Torque Range (lb-ft)	1250-1525 (1700-2074 Nm)
Idle RPM	800
Governed RPM	2300
High Idle RPM	2425

KEY FEATURES

Premium Medium-Duty Commercial Construction

- JP8 compatible
- Single turbocharger, variable geometry turbine
- Generation 2, electro hydraulic fuel system
- Electronic Control Module (ECM)
- Wet replaceable sleeves
- One piece steel pistons
- Cam roller followers
- SAE #1 and #2 flywheel housing
- Diamond Logic electronic control features
- J1939 datalink compatible; diagnostic data stored in ECM
- Cold weather ambient protection; service assistant
- Remote "2" Preset PTO Engine Speed
- Remote variable engine speed control
- Engine weight (dry): 1425lbs (646.37kg)

MARKET AVAILABILITY

- Medium Wheeled Military Vehicles
- Medium Tracked Military Vehicles
- Gensets

MAXXFORCE 9.3 D POWER PACK AVAILABLE

- Transmissions
- Cooling System
- Full Accessory Options
- Driveline Components

ENGINE DIMENSIONS

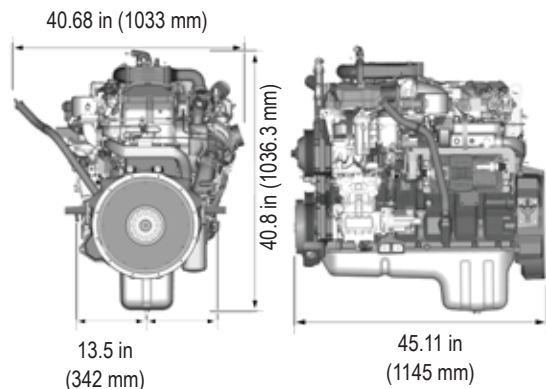

MAXXFORCE 9.3D HORSEPOWER / TORQUE CURVES

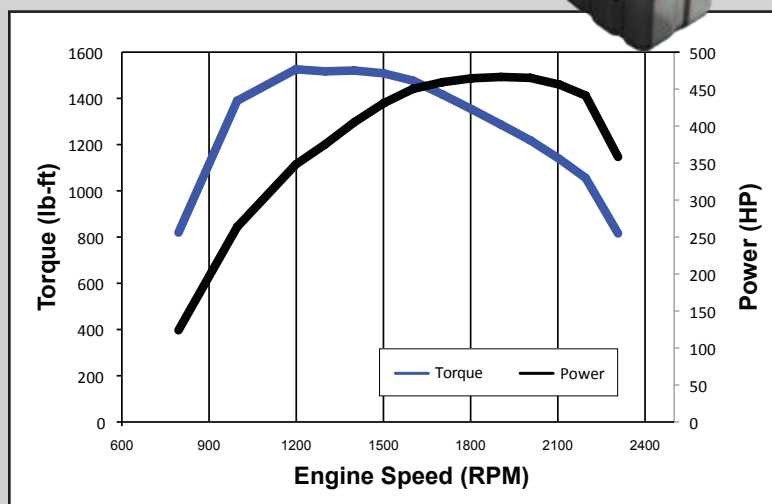

MAXXFORCE 9.3D POWERED VEHICLES



MaxxPro Plus



MaxxPro Wrecker



MaxxPro DASH